



RGP300

Output Rating - 50 HZ		
Voltage, Frequency	Prime	Standby
230/400V, 50HZ	300 KVA 240 KW	330 KVA 264 KW

Output Rating - 60 HZ		
Voltage, Frequency	Prime	Standby
230/400V, 60HZ	383 KVA 306.4 KW	421.3 KVA 337.04 KW

Output Rating - 60 HZ		
Voltage, Frequency	Prime	Standby
227/480V, 60HZ	400 KVA 320 KW	440 KVA 352 KW



Image for illustration purposes only.

Rating at 0.8 power factor

Features	
Engine	Perkins , 1506A-E88TAG5 , Made in UK, in accordance to ISO3046 ,ISO8528,DIN6271
Alternator	Stamford HC444E , Made in UK,Or Le Roy Somer TAL 046F Made in Europe complying to the norms: BS EN60034/ BS 5000/ VDE 0530/ NEMA MG 1-32/ IEC 34/ CSA C22.2-100/AS 1359
Control Panel	MRM 17-1 ,Made in ITALY,or DeepSea Made in UK, complying to the norms: comply to the norms BS EN 61000, BS EN 60950, BS EN 60068
Base Frame	Black steel with Anti-vibration pads, Built in fuel tank
Sound Proof Canopy	Modular SPC, Powder Coated, Extremely Durable, Designed to Reduce Sound Level with Maximum Service Accessibility and Minimum Foot Prints
Worldwide Support	RG Power Products are distributed through its RG Power International Network

Rating Definitions and Conditions	
Prime Rating	The power available for an unlimited hour usage with an average load factor of 80% of the published prime power over each 24 hours period. A 10 % overload is available for 1Hr every 12 hours.
Standby Rating	The power limited to 500 hours annual usage with an average load factor of 80% of the published standby power rating over each 24-hour period. Up to 300 hours of annual usage may be run continuously. No overload is permitted on standby power.

Engine Perkins, 1506A-E88TAG5, 4 Stroke Cycle, Diesel

Structure	Number of Cylinders	6	
	Engine Build	In line	
	Bore	130 mm	
	Stroke	157 mm	
	Displacement	12.5 L.	
	Compression Ratio	16.3/1	
	Aspiration	Turbocharged	
	Cooling	A/A	
Fuel		1500 RPM	1800 RPM
	Fuel Tank	Built in fuel tank 587L for 7hours operation @ full load	Built in fuel tank 587L for 7hours operation @ full load
	Fuel System	Direct injection	
	Fuel Recommended	N°2 Diesel	
	Fuel System Make (ECM)	-	
		1500 RPM	1800 RPM
	Delivery Flow Rate (l/hr)	TBA	NA
	Fuel Consumption		
	100% Load (g/kWh-L/hr)	196 (71)	196 (81)
	75% Load (g/kWh-L/hr)	198 (54)	199 (62)
	50% Load (g/kWh-L/hr)	203 (37)	205 (43)
	Cooling system	Engine Coolant Capacity	51.4L
Air Flow-Radiator		10900 l/s	13133 l/s
Radiator with 50 degree ambient			
Cooling Package & Air Cleaner Kit			
Thermostatically-controlled system			
Air Inlet	Air Intake Engine (Clean Filter/Dirty)	2.5/6.2 kPa	
Exhaust System	Exhaust Gas Temperature (Prime)	630 °C	630 °C
	Exhaust Gas Flow (Prime)	934.3 l/s	1125 l/s
	Maximum Exhaust System Back Pressure	6.8 kPa	6.8 kPa
	Muffler	residential (20→25 dB)	industrial(15→25 dB)
	Stainless Steel exhaust flex-fittings		
DC System-Starting/Charging	Cranking Battery Voltage	24 V	
	Battery Charging Alternator	70 A	
	Dc Voltage Monitoring via control		
Heat Rejection (prime)	Radiated Heat to Ambient (Prime)	24.1 kW	40.3 kW
	Heat Rejection to Coolant (Prime)	113.5 kW	130.2 kW
	Heat Rejection to Exhaust (Prime)	213.2 kW	244.7 kW
	Heat Rejection to intercooler	64.8 kW	64.8 Kw
Lube System	Lubricating System Oil Capacity	40 L	
Governor	Electronic		

Alternator Stamford , HC444E Or Le Roy Somer TAL 046F

Structure	Insulation System	Class H
	Winding Pitch	2/3 to minimize harmonics effects
	Number of Poles	4
	Number of Bearings	Single bearing
	Winding Leads	12
	Power Factor	0.8
	Over Speed Capability (% of Rated)	2250 Rpm (150%)
	Wave Form Distortion	THD(Total Harmonic Distortion)@ No load < 5.0%
	Telephone Interference	TIF < 2%
	IP Rating (Protection)	IP23
	AVR	Self excited
	Synchronous, 3 phase, Brushless & Self ventilated	

		1500 RPM	1500 RPM
Power Switching	3-P Circuit Breaker, MCB	630A	630A
Temperature	Temperature Rise	125/40 °C	
Control & Voltage Regulator	Control System (Standard)	Self excited	
	Voltage Regulator (AVR)	SX460 OR AS440 / R150	
	% Of Voltage Regulation	± 1.0 %	
Motor Starting Capacity@30% Voltage Dip	if voltage 230/400V	TBA	
	if voltage 277/480V	TBA	

Standard Controller, MRM17-1		
Control	<ul style="list-style-type: none"> Fuel tank monitoring Emergency Stop Pushbutton/ Alarm Acknowledge Engine Cool Down Timer Warm-up Timer Load Switching Timer Engine Cycle Crank 	
Indications	<ul style="list-style-type: none"> Operating Hours 3 Phase Generator Voltage Sensing & Monitoring Current Protection & Monitoring Power Measurement (kW, kVA, kVA_r, kWh, kVAh, kVA_rh, pf) Frequency Monitoring (Hz) Oil Pressure/Coolant Temperature/Fuel Level Monitoring Battery Voltage Monitoring (DC) Alarm Acknowledge 	
Warning & Shutdown Alarms	<ul style="list-style-type: none"> Generator Over/Under Voltage & Frequency Crank Disconnect (Failure to Start) Under/Over Speed Over Current Low oil pressure High Water Temperature Low Fuel Level Low Water Level 	
Features	<ul style="list-style-type: none"> IP 65 (if ordered with gasket) Basic Scheduler 8-35 VDC Supply Digital Inputs(4)- Outputs(4 MPU/ 6 CAN) Event Log (5 shutdowns) 	
Optional Accessories		
Alternator	<ul style="list-style-type: none"> AVR (3 phase Sensing) Reactive Droop Winding Temperature Detectors Anti- Condensation Heaters Excitation with auxiliary exciter (PMG) 	
Warning & Shutdown Alarms	<ul style="list-style-type: none"> 4-P Circuit Breaker Special Brands (ABB- MG- Siemens...) Motorized Operation Shunt Trip Under Voltage Trip UVT Residual Current Protection Ground Fault Protection Earthing Kit Surge Arrestor 	

Optional Accessories (continues)	
Engine	Fuel Micro-Diesel Filter for Micro-Particles Filtration Automatic Fuel Refilling System Fuel Water Separator (2000/18) Mechanical Fuel Level Kit Oversize Fuel Tank Upon Custom Requirements Fuel Tanks-Pipes Heater Optional Built in fuel tank 62 L operation full load (Height will be increased by 100 mm and weight by 20 kg)
	Air Inlet Sy-klone Air Cleaner Installed @ Air Intake System
	Exhaust Muffler: Critical (25→30 dB) Hospital (35→40 dB) Elbow, Flanges, Expanders & Y Adaptors
	Cooling / Heating Radiator with 35 °C or 60 °C Ambient Capability Jacket Water Heater
	Lube Manual Sump Drain Pump Semi-Rotator Hand Pump
	DC System - Starting/Charging Mains Battery Charger 24 V DC-5A Battery Charger 10A-20A on Request Automatic Battery Charger on Request Battery Disconnect Switch DC/AC Current Monitoring (Ammeter) Oversize Battery
Control Panel	DSE 7310/7320/7410/7420-More Inputs & Outputs-Advanced Communications Features; DSE 8610/8710/8810- Load Share Module; Digital & Analogues Inputs Module DSE 2130 (for 7000 Series & Above); Analogue Inputs advanced Module DSE 2131-2133(for 7410 &Above); Digital relay Outputs Module DSE 2157 (for 7000 Series &Above); Analogue Outputs Module DSE 2152 (for 7410 & Above); Local & Remote enunciator Module DSE 2548 (for 7000 Series & Above); Display Modules DSE 2510/2520 (with 7310-7320); Remote Monitoring via: Web Interface (All Series), GSM (for 7000 Series & Above), RS485 (for 7000 Series) Dry Contacts Alarm Indication for Customer Use Audible Alarm (Option for 6010/20; Standard for 7000 Series & Above); Voltage Adjust Potentiometer; Speed Adjust Potentiometer;

Dimensions & Weights

	Length (mm)	Width (mm)	Height (mm)	Weight Dry (Kg)
Open set (NB)	3600	1410	2187	3055
SPC Type	5623	1410	2484	4309

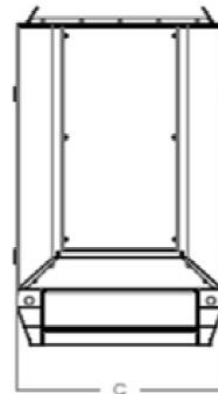
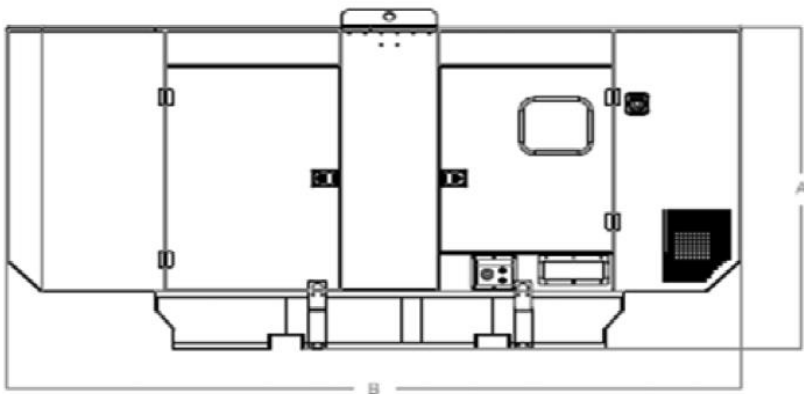
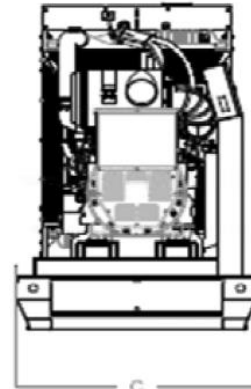
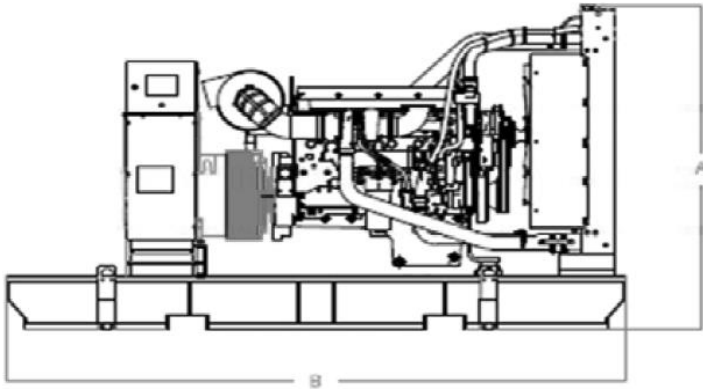

Design for illustration purposes only.

In line with our policy of continuous product development, we reserve the right to change specification without notice.