

# RGP2250

## Output Rating - 50 HZ

Voltage, Frequency	Prime	Standby
230/400V, 50HZ	2250 KVA 1800 KW	2,500 KVA 2000 KW

## Output Rating - 60 HZ

Voltage, Frequency	Prime	Standby
230/400V, 60HZ	NA NA	NA NA

## Output Rating - 60 HZ

Voltage, Frequency	Prime	Standby
277/480V, 60HZ	NA NA	NA NA



Image for illustration purposes only.

Rating at 0.8 power factor

## Features

Engine	Perkins , 4016-61TRG3 , Made in UK, in accordance to ISO3046 ,ISO8528,DIN6271
Alternator	Stamford PI734G , Made in UK, Or Le Roy Somer LSA 52.3 L90 complying to the norms: BS EN60034/ BS 5000/ VDE 0530/ NEMA MG 1-32/ IEC 34/ CSA C22.2-100/AS 1359
Control Panel	MRM 17-1 ,Made in ITALY,or DeepSea 7320 Made in UK, complying to the norms: comply to the norms BS EN 61000, BS EN 60950, BS EN 60068
Base Frame	Black steel with Anti-vibration pads, Built in fuel tank
Sound Proof Canopy	Modular SPC, Powder Coated, Extremely Durable, Designed to Reduce Sound Level with Maximum Service Accessibility and Minimum Foot Prints
Worldwide Support	RG Power Products are distributed through its RG Power International Network

## Rating Definitions and Conditions

Prime Rating	The power available for an unlimited hour usage with an average load factor of 80% of the published prime power over each 24 hours period. A 10 % overload is available for 1Hr every 12 hours.
Standby Rating	The power limited to 500 hours annual usage with an average load factor of 80% of the published standby power rating over each 24-hour period. Up to 300 hours of annual usage may be run continuously. No overload is permitted on standby power.

**Engine Perkins, 4016-61TRG3, 4 Stroke Cycle, Diesel**

<b>Structure</b>	<b>Number of Cylinders</b>	16	
	<b>Engine Build</b>	60 ° V	
	<b>Bore</b>	160 mm	
	<b>Stroke</b>	190 mm	
	<b>Displacement</b>	61.123 L	
	<b>Compression Ratio</b>	13 /1	
	<b>Aspiration</b>	Turbocharged	
	<b>Cooling</b>	A /W	
<b>Fuel</b>		<b>1500 rpm</b>	<b>1800 rpm</b>
	<b>Fuel Tank</b>	NA	NA
	<b>Fuel System</b>	Direct injection	
	<b>Fuel Recommended</b>	N°2 Diesel	
	<b>Fuel System Make (ECM)</b>	-	
		<b>1500 rpm</b>	<b>1800 rpm</b>
	<b>Delivery Flow Rate (l/hr)</b>		
	<b>Fuel Consumption</b>		
	<b>100% Load (g/kWh-L/hr)</b>	209 (436.8)	NA
	<b>75% Load (g/kWh-L/hr)</b>	203(316)	NA
	<b>50% Load (g/kWh-L/hr)</b>	202 (211.1)	NA
<b>Cooling system</b>	<b>Engine Coolant Capacity</b>	316L	
	<b>Air Flow-Radiator</b>	40500 l/s	NA
	Radiator with 50 degree ambient		
	Cooling Package & Air Cleaner Kit		
	Thermostatically-controlled system		
<b>Air Inlet</b>	<b>Air Intake Engine (Clean Filter/Dirty)</b>	1.2 / 3.7 Kpa	
<b>Exhaust System</b>	<b>Exhaust Gas Temperature (Prime)</b>	475 °C	NA
	<b>Exhaust Gas Flow (Prime)</b>	8166.6 l/s	NA
	<b>Maximum Exhaust System Back Pressure</b>	4 kPa	NA
	<b>Muffler</b>	residential (20→25 dB)	industrial(15→25 dB)
	Stainless Steel exhaust flex-fittings		
<b>DC System-Starting/Charging</b>	<b>Cranking Battery Voltage</b>	2*24 V	
	<b>Battery Charging Alternator</b>	40 A	
	Dc Voltage Monitoring via control		
<b>Heat Rejection (prime)</b>	<b>Radiated Heat to Ambient (Prime)</b>	135 kW	NA
	<b>Heat Rejection to Coolant (Prime)</b>	757 kW	NA
	<b>Heat Rejection to Exhaust (Prime)</b>	1400 kW	NA
	<b>Heat Rejection to intercooler</b>	684 Kw	NA
<b>Lube System</b>	<b>Lubricating System Oil Capacity</b>	237.2 L	
<b>Governor</b>	Electronic		

**Alternator Stamford PI734G Or Le Roy Somer LSA 52.3 L90**

<b>Structure</b>	<b>Insulation System</b>	Class H	
	<b>Winding Pitch</b>	2/3 to minimize harmonics effects	
	<b>Number of Poles</b>	4	
	<b>Number of Bearings</b>	Single bearing	
	<b>Winding Leads</b>	6	
	<b>Power Factor</b>	0.8	
	<b>Over Speed Capability (% of Rated)</b>	2250 Rpm (150%)	
	<b>Wave Form Distortion</b>	<b>No load &lt; 1.5% Non-Distorting balanced linear load &lt; 5.0%</b>	
	<b>Telephone Interference</b>	THF < 2%	
	<b>IP Rating (Protection)</b>	IP23	
	<b>AVR</b>	Separately excited by PMG	
Synchronous, 3 phase, Brushless & Self ventilated			
		<b>1500 rpm</b>	<b>1800 rpm</b>
<b>Power Switching</b>	3-P Circuit Breaker, ACB	3200A	NA
<b>Temperature</b>	<b>Temperature Rise</b>	125/40 °C	
<b>Control &amp; Voltage Regulator</b>	<b>Control System (Standard)</b>	Separately excited by PMG	
	<b>Voltage Regulator (AVR)</b>	MX321(3 phase sensing) or MX341(1 phase sensing)	
	<b>% Of Voltage Regulation</b>	± 0.5 % (for MX321) / ± 1.0 % (for MX341) Or R450	
<b>Motor Starting Capacity@30% Voltage Dip</b>	if voltage 230/400V	TBA	
	if voltage 277/480V	TBA	

Standard Controller, MRM17-1 Or DeepSea 7320		
<b>Control</b>	<ul style="list-style-type: none"> <li>Fuel tank monitoring</li> <li>Emergency Stop Pushbutton/ Alarm Acknowledge</li> <li>Engine Cool Down Timer</li> <li>Warm-up Timer</li> <li>Load Switching Timer</li> <li>Engine Cycle Crank</li> </ul>	
<b>Indications</b>	<ul style="list-style-type: none"> <li>Operating Hours</li> <li>3 Phase Generator Voltage Sensing &amp; Monitoring</li> <li>Current Protection &amp; Monitoring</li> <li>Power Measurement (kW, kVA, kVA<sub>r</sub>, kWh, kVAh, kVA<sub>r</sub>h, pf)</li> <li>Frequency Monitoring (Hz)</li> <li>Oil Pressure/Coolant Temperature/Fuel Level Monitoring</li> <li>Battery Voltage Monitoring (DC)</li> <li>Alarm Acknowledge</li> </ul>	
<b>Warning &amp; Shutdown Alarms</b>	<ul style="list-style-type: none"> <li>Generator Over/Under Voltage &amp; Frequency</li> <li>Crank Disconnect (Failure to Start)</li> <li>Under/Over Speed</li> <li>Over Current</li> <li>Low oil pressure</li> <li>High Water Temperature</li> <li>Low Fuel Level</li> <li>Low Water Level</li> </ul>	
<b>Features</b>	<ul style="list-style-type: none"> <li>IP 65 (if ordered with gasket)</li> <li>Basic Scheduler</li> <li>8-35 VDC Supply</li> <li>Digital Inputs(4)- Outputs(4 MPU/ 6 CAN)</li> <li>Event Log (5 shutdowns)</li> </ul>	
Optional Accessories		
<b>Alternator</b>	<ul style="list-style-type: none"> <li>AVR (3 phase Sensing)</li> <li>Reactive Droop</li> <li>Winding Temperature Detectors</li> <li>Anti- Condensation Heaters</li> <li>Excitation with auxiliary exciter</li> </ul>	
<b>Warning &amp; Shutdown Alarms</b>	<ul style="list-style-type: none"> <li>4-P Circuit Breaker</li> <li>Special Brands (ABB- MG- Siemens...)</li> <li>Motorized Operation</li> <li>Shunt Trip</li> <li>Under Voltage Trip UVT</li> <li>Residual Current Protection</li> <li>Ground Fault Protection</li> <li>Earthing Kit</li> <li>Surge Arrestor</li> </ul>	

Optional Accessories (continues)	
<b>Engine</b>	<b>Fuel</b> Micro-Diesel Filter for Micro-Particles Filtration Automatic Fuel Refilling System Fuel Water Separator <b>(2000/40)</b> Mechanical Fuel Level Kit Oversize Fuel Tank Upon Custom Requirements Fuel Tanks-Pipes Heater Optional Built in fuel tank 180 L operation full load (Height will be increased by 100 mm and weight by 20 kg)
	<b>Air Inlet</b> Sy-klone Air Cleaner Installed @ Air Intake System
	<b>Exhaust</b> Muffler: Critical (25→30 dB) Hospital (35→40 dB) Elbow, Flanges, Expanders & Y Adaptors
	<b>Cooling / Heating</b> Radiator with 35 °C or 60 °C Ambient Capability Jacket Water Heater
	<b>Lube</b> Manual Sump Drain Pump Semi-Rotator Hand Pump
	<b>DC System - Starting/Charging</b> Mains Battery Charger 24 V DC-5A Battery Charger 10A-20A on Request Automatic Battery Charger on Request Battery Disconnect Switch DC/AC Current Monitoring (Ammeter) Oversize Battery
<b>Control Panel</b>	7320/7410/7420-More Inputs & Outputs-Advanced Communications Features; DSE 8610/8710/8810- Load Share Module; Digital & Analogues Inputs Module DSE 2130 (for 7000 Series & Above); Analogue Inputs advanced Module DSE 2131-2133(for 7410 &Above); Digital relay Outputs Module DSE 2157 (for 7000 Series &Above); Analogue Outputs Module DSE 2152 (for 7410 & Above); Local & Remote enunciator Module DSE 2548 (for 7000 Series & Above); Display Modules DSE 2510/2520 (with 7310-7320); Remote Monitoring via: Web Interface (All Series), GSM (for 7000 Series & Above), RS485 (for 7000 Series) Dry Contacts Alarm Indication for Customer Use Audible Alarm (Option for 6010/20; Standard for 7000 Series & Above); Voltage Adjust Potentiometer; Speed Adjust Potentiometer;

Dimensions & Weights

	Length (mm)	Width (mm)	Height (mm)	Weight Dry (Kg)
Open set	7000	2740	3020	15700
SPC Type	12000	3500	3500	21700

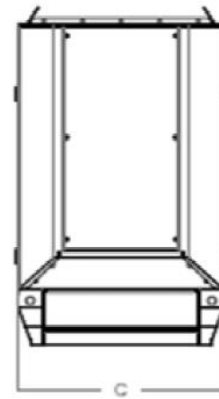
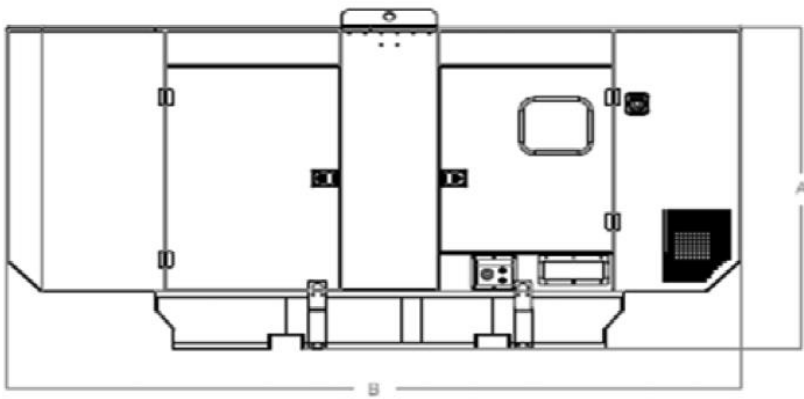
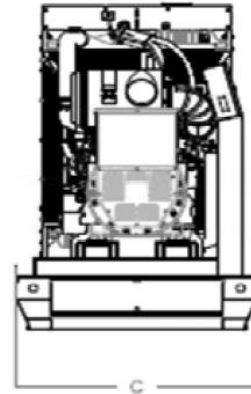
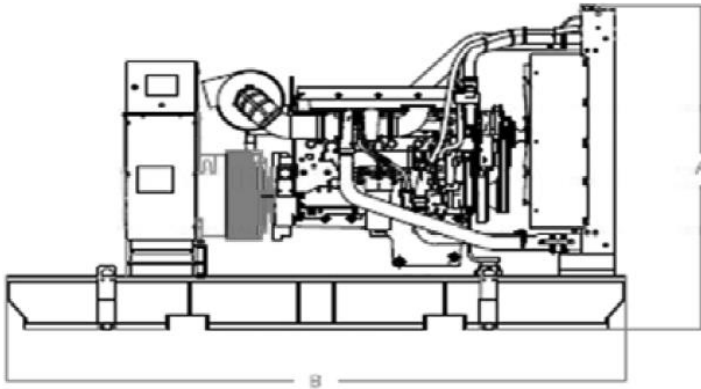

Design for illustration purposes only.

In line with our policy of continuous product development, we reserve the right to change specification without notice.